

48-1

UN970229-BD

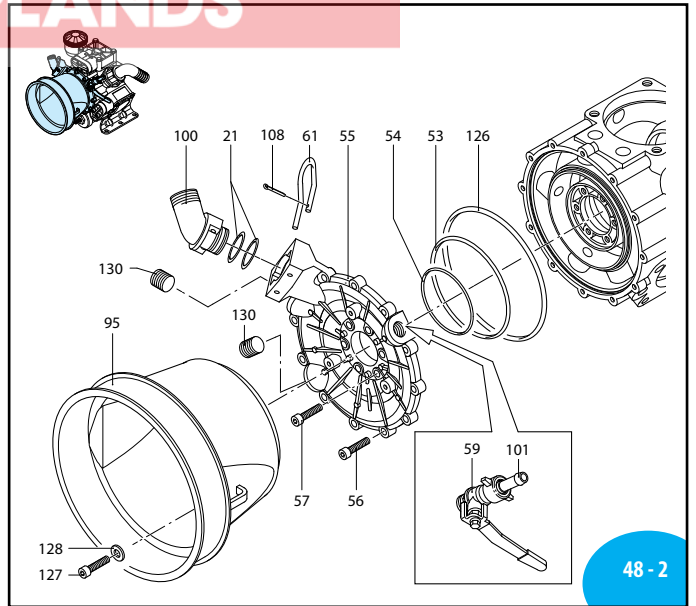

48-2

UN970230-BD

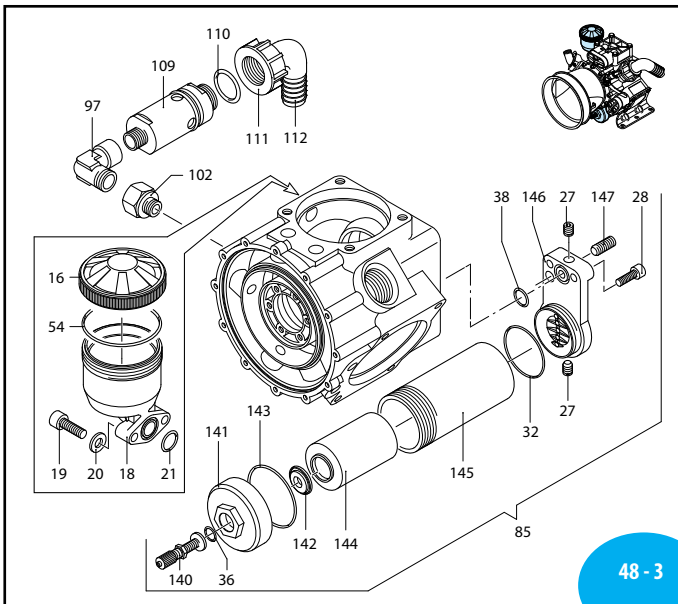

48-3

UN970231-BD

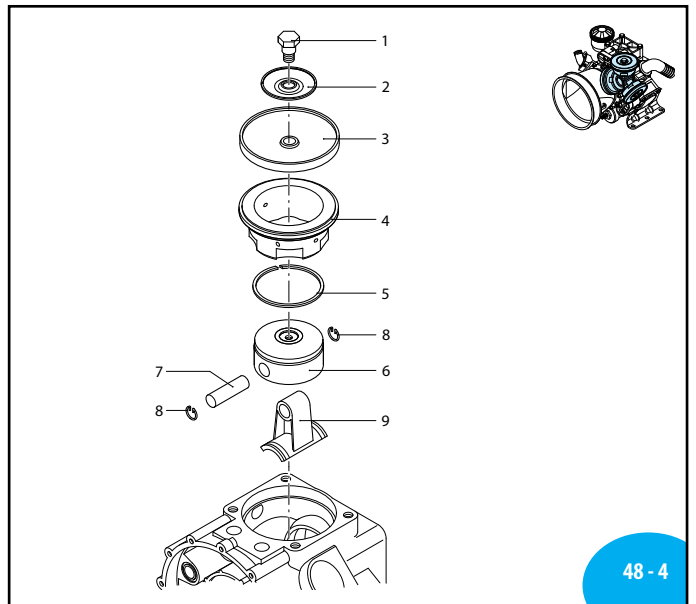

48-4

UN970249-BD

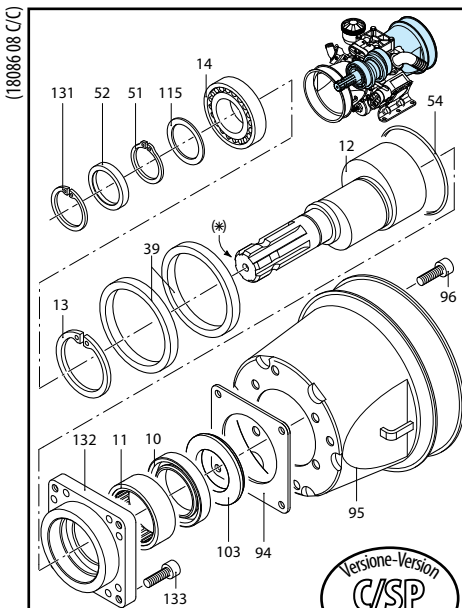

Versione-Version
C/SP

UN970170-BD

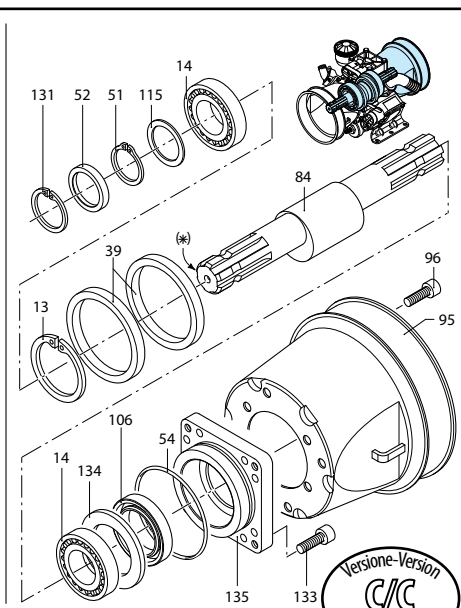

Versione-Version
C/C

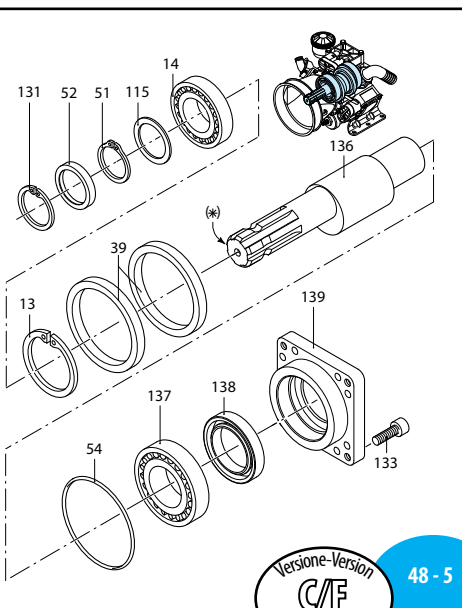

Versione-Version
C/F

48-5

AR 813

Pos.	Cod.	Descrizione	Description	Q.ty	Note
1	580361	Perno membrana	Diaphragm pin	3	● C ₃₀
2	1040180	Piastra di richiamo	Plate	3	
3	1040080	Membrana	Diaphragm	3	Desmopan
4	1040081	Membrana	Diaphragm	3	Gomma
5	1500080	Camicia	Sleeve	3	
6	650190	Segmento	Piston ring	3	
7	1040120	Pistone	Piston	3	
8	1040070	Spinotto	Piston pin	3	
9	1040270	Anellino spinotto	Pin ring	6	
10	1800050	Biella	Connecting rod	3	
11	1400150	Anello tenuta	Seal ring	1	
12	650200	Cuscinetto a rullini	Roller bearing	1	
13	1800200	Albero eccentrico "C/SP"	"C/SP" shaft	1	(34)
14	161050	Anello seeger	Circlip	1	
15	161060	Cuscinetto	Bearing	2	
16	1040551	Testa DX	Right head	2	
17	1800060	Tappo serbatoio nero	Black oil tank cap	1	
18	680031	Serbatoio olio	Oil tank	1	
19	680350	Vite TCEI M 8x35	Bolt	2	C ₁₀
20	380241	Rosetta ø 8,5	Washer	2	
21	390180	OR ø 18,72x2,62	O-Ring	3	▶
22	1040552	Testa SX	Left head	1	
23	1480040	Vite TE M 12x60	Bolt	4	C ₅₀
24	1800440	Piede SX	Left base	1	
25	750060	Vite TE M 12x65	Bolt	8	● C ₅₀
26	1040470	Grano M 10x8	Dowel	2	C ₁₀
27	320360	Vite TCEI M 8x22	Bolt	2	C ₂₀
28	1409050	Valvola completa	Complete valve	6	
29	540360	OR ø 44,12x2,62	O-Ring	1	▶
30	650542	Guarnizione	Gasket	1	▶
31	640070	OR ø 13,95x2,62	O-Ring	1	▶
32	1040340	Anello biella	Con rod ring	2	
33	1800140	Corpo pompa	Pump body	1	
34	250310	OR ø 36,14x2,62	O-Ring	2	▶
35	540530	Niples 1"1/4-1"3/4 G (M)	Threaded adapter	1	
36	770571	OR ø 18,77x1,78	O-Ring	6	Viton ▶
37	540540	Girello 1"3/4 G	Ring nut	1	
38	540550	Curva ø 40	Elbow	1	
39	1040570	Anello seeger	Circlip	1	
40	1040050	Anello tenuta	Seal ring	1	
41	1800161	OR ø 113,97x2,62	O-Ring	1	Viton ▶
42	1040060	OR ø 72,69x2,62	O-Ring	3	▶
43	1800150	Condotta mandata	Manifold	1	
44	1040370	Vite TCEI M 6x22	Bolt	12	C ₁₀
45	780060	Vite TCEI M 6x25	Bolt	6	C ₁₀
46	130491	Rub. 3/8"-1/2" G (M) DX	Right valve	1	ex 30491
47	1040690	Forcella	Fork	1	
48	620030	OR ø 25,80x3,53	O-Ring	6	▶

Pos.	Cod.	Descrizione	Description	Q.ty	Note
49	1800180	Albero eccentrico "C/C"	"C/C" shaft	1	(W)
50	1536	Camera aria completa	Complete air chamber	1	
51	1800430	Piede DX	Right base	1	
52	1400140	Flangia anello tenuta	Flange	1	
53	1500350	Protezione cardano	Cardan protection	2	ø 199 mm
54	1500470	Protezione cardano	Cardan protection	2	ø 239 mm
55	820670	Vite TCEI M 10x16	Bolt	4	C ₁₀
56	881560	Gomito 90° 1/2" G (M)-(F)	Elbow	1	■
57	1300190	Tappo valvola	Valve cap	3	
58	620610	Vite TCEI M 8x30	Bolt	6	C ₅₀
59	1040760	Attacco 3/4" G	Coupling	1	
60	110131	Racc. 1/2" G+hose ø10	Fitting 1/2" G+hose ø10	1	ex 10131
61	881461	Manic. 3/8"-1/2" G (M)-(F)	Threaded adapter	1	■
62	1400110	Centraggio flangia "C/SP"	"C/SP" flange spigot	1	
63	540361	OR ø 33,05x1,78	O-Ring	6	▶
64	160740	Anello tenuta	Seal ring	1	
65	1040950	Copiglia	Split pin	1	
66	1609002	Valvola di sicurezza	Safety valve	1	■
67	880831	OR ø 15,54x2,62	O-Ring	1	Viton ▶
68	550450	Girello 3/4" G	Ring nut	1	
69	550460	Curva ø 18	Elbow	1	
70	1040850	Anello	Ring	1	
71	1400120	OR ø 145,72x2,62	O-Ring	1	▶
72	1343510	Vite TCEI M 6x14	Bolt	3	C ₁₀
73	881710	Rosetta ø 6	Washer	3	
74	1040260	Grano M 10x25	Dowel	1	● C ₁₀
75	1800240	Grano 3/8" G	Dowel	2	● C ₁₀
76	1460490	Anello seeger	Circlip	1	
77	1800210	Flangia albero "C/SP"	Flange "C/SP" version	1	
78	180030	Vite TCEI M 8x20	Bolt	8	● C ₁₀
79	1800230	Distanziale	Spacer	1	
80	1800220	Flangia albero "C/C"	Flange "C/C" version	1	
81	1800190	Albero eccentrico "C/F"	"C/F" shaft	1	(Q)
82	230310	Cuscinetto	Bearing	1	
83	200150	Anello tenuta "C/F"	Seal ring "C/F"	1	
84	1800120	Flangia albero "C/F"	Flange "C/F" version	1	
85	1800350	Valvola di gonfiaggio	Air valve	1	
86	1800270	Coperchio camera aria	Air chamber cover	1	
87	1800311	Disco	Plate	1	
88	650560	OR ø 56,82x2,62	O-Ring	1	▶
89	1800300	Semicamera aria	Semi air chamber	1	
90	1800280	Tubo camera aria	Air chamber tube	1	
91	1800290	Attacco camera aria	Air chamber connector	1	
92	1040260	Grano M 10x25	Dowel	1	C ₁₀

Alta Pressione
High Pressure

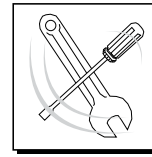
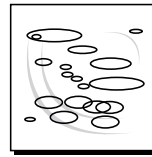
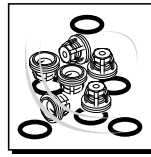

KIT 1952 Membrane gomma Buna diaphragms	
Pos.	Q.ty
3	3

KIT 1963 Valvole Valves	
Pos.	Q.ty
31	6
70	6

KIT 2376 OR O-Rings			
Pos.	Q.ty	Pos.	Q.ty
21	3	126	1
32	1	143	1
38	1		
44	2		
46	6		
53	1		
54	3		
70	6		
104	6		
110	1		

KIT 2377 Pronto intervento Maintenance repair					
Pos.	Q.ty	Pos.	Q.ty	Pos.	Q.ty
1	3	44	2	106	1
3	3	46	6	108	1
10	1	47	1	126	1
16	1	48	1	144	1
18	1	52	1		
21	3	53	1		
31	6	54	3		
32	1	61	1		
36	1	70	6		
38	1	104	6		

Olio utilizzato Used oil	
Tipo - Type	Kg
SAE 30	1

NOTE
SOME PARTS ARE NON-STOCK
ITEMS AND MAY NEED TO BE
ORDERED

NOTE
PLEASE ADD PREFIX **AR**
TO REFLECT CROPLANDS
PART NUMBER

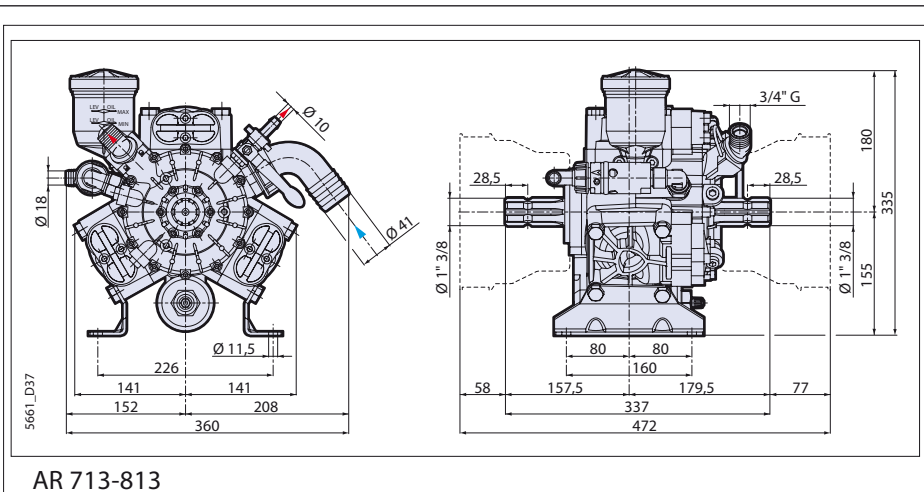

AR 713-813

DIMENSIONS • DIMENSIONI 5661_D37

<h1 style="margin: 0;">AR 713-813</h1>	<p>Pumps Pompe</p>
--	------------------------

Nelle pompe C/SP la quota @ 17 si riduce a 15 con la flangia anello tenuta montata sul corpo pompa.
 N.B.: togliere la flangia anello tenuta cod. 1400140 prima di accoppiare il riduttore alla pompa.
 In C/SP pumps the value @ 17 is reduced to 15 with the seal ring flange mounted on the pump body.
 N.B.: remove the seal ring flange code 1400140 before fitting the reduction gear to the pump.
 Dans les pompes C/SP la cote @ 17 se réduit à 15 avec la bride bague d'étanchéité montée sur le corps de la pompe. N.B.: enlever la bride bague d'étanchéité code 1400140 avant d'accoupler le réducteur à la pompe.

Please note: specifications are subject to change for improvement without notice.
 © Giu 2007 by AnnoviReverberi spa

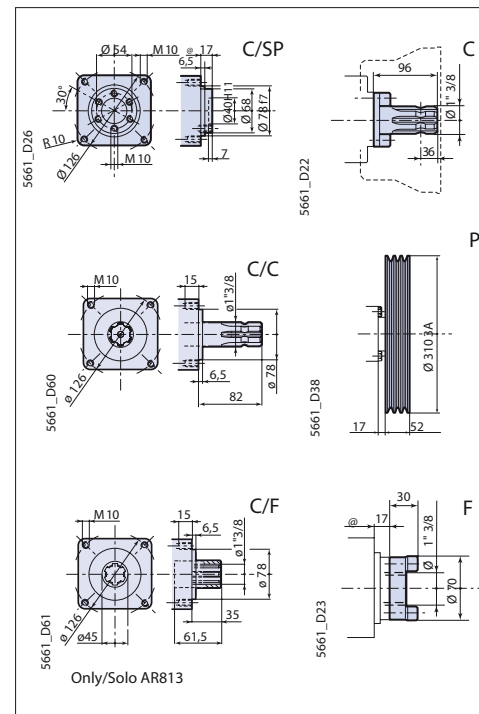

Only/Solo AR813

Bei den C/SP Pumpen verringert sich das Maß @ 17 auf 15 bei dem auf den Pumpenkörper montierten Flansch des Dichtungsring. Anmerkung: Den Dichtungsring mit Kode 1400140 vor der Anknüpfung des Untersetzungsgetriebe an die Pumpe entfernen.
 En las bombas C/SP la cota @ 17 se reduce a 15 con la brida anillo de retención montada en el cuerpo de la bomba. NOTA: quitar la brida anillo de retención cód. 1400140 antes de conectar el reductor a la bomba.